

ON/OFF-ROAD

R-7830 Backwall

Air Conditioner Unit

VANS • COMMERCIAL TRUCKS • INDUSTRIAL • CONSTRUCTION • AGRICULTURE

The R-7830 easily fits between the seats to mount to a bulkhead or back wall of a day cab, or can be front-dash mounted where a flat space permits. The welded steel housing provides protection yet allows easy access to components. Multidirectional diffusers send air where you need it. Floor support kit available.



HEATER-A/C

R-7830 SPECIFICATIONS

BTUs	Cooling – 17,180 BTU/Hr with 36°F (5 kW with 2.2°C) refrigerant temperature and 80°F (26.7°C) wet bulb entering air
AIR FLOW	260 CFM (442 m ³ /h)
WEIGHT	25 lbs. (11 kg)
CURRENT	18 amps @ 13.6 VDC (includes 4 amps for A/C clutch);
DRAW	9 amps @ 27.2 VDC (including 2 amps for A/C clutch)
CONTROLS	High-low motor speed, four adjustable louvers, adjustable thermostat

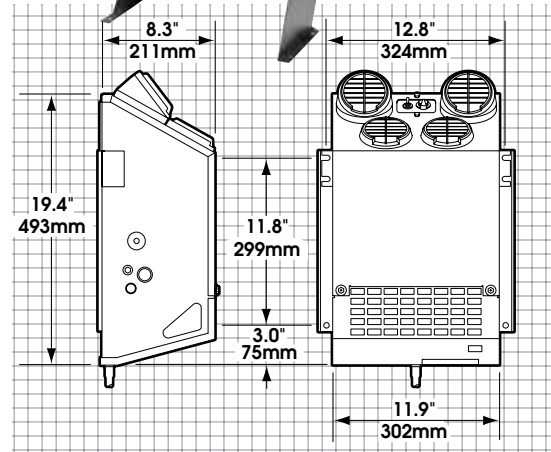

R-7830 SYSTEM ORDERING GUIDE

	R-134a	NOTES	
UNITS	R-7830-0P R-7830-0-24P	12 VDC – Variable Thermostat 24 VDC – Variable Thermostat	
CONDENSER	R-6160-0P - Roof Mount R-6160-0-24P - Roof Mount 77R0650 - Radiator Mount	12 VDC – See page 58 24 VDC – See page 58 See page 448	
INSTALLATION KIT	78R1070 78R1077 78R1027 78R1025	Rooftop condenser Rooftop condenser Front mount condenser Front mount condenser	ATCO version EZ Clip version EZ Clip version ATCO version
OPTIONS	Floor Support Kit Recirc Filter Kit	RD-2-1398-0P 78R5390	
COMPRESSOR	Requires compressor and mounting kit		See 75 Series Compressor section on page 329